

# Robot PROMOBOT v.4.0



**promobot**

## User guide

Serial Number:





# Table of Contents

---

<b>1. Basic parameters</b> .....	<b>5</b>
1.1. Specifications .....	5
1.2. Contents of delivery .....	6
1.3. Web services .....	8
1.4. Application area .....	8
1.5. Conventions .....	9
1.6. General safety rules .....	8
1.7. Storage conditions .....	9
1.8. Visual control .....	9
1.9. Safety precautions .....	10
1.10. Electrical safety .....	10
1.11. Technical requirements .....	12
1.11.1. Requirements for the location .....	12
1.11.2. Requirements for preparing the location for the work of Promobot .....	13
1.12. Transportation conditions .....	15
1.13. Navigation conditions .....	12
1.13.1. Requirements for floor covering .....	12
1.13.2. Requirements for walls and interior .....	12
1.13.3. Requirements for placing the charging station .....	13
<b>2. Arrangement and components</b> .....	<b>20</b>
2.1. Head .....	20
2.2. Torso .....	22
2.3. Hand-operated manipulators .....	24
2.4. Movement platform .....	26
2.5. Operational ports .....	28
<b>3. Operation</b> .....	<b>29</b>
3.1. Safety measures before commissioning .....	29
3.2. Commissioning .....	29
3.3. Launch of Promobot .....	44
3.4. The use of Controller .....	47
3.5. End of work. Charging station .....	48
3.6. Transportation .....	49
3.7. Printing photos .....	50
3.8. Printing receipts .....	53
3.9. Use of the Banking Terminal .....	56
3.10. Card dispenser .....	57
<b>4. Periodic maintenance</b> .....	<b>58</b>
<b>5. Warranty conditions</b> .....	<b>60</b>

# 1. Basic parameters

## 1.1. Specifications

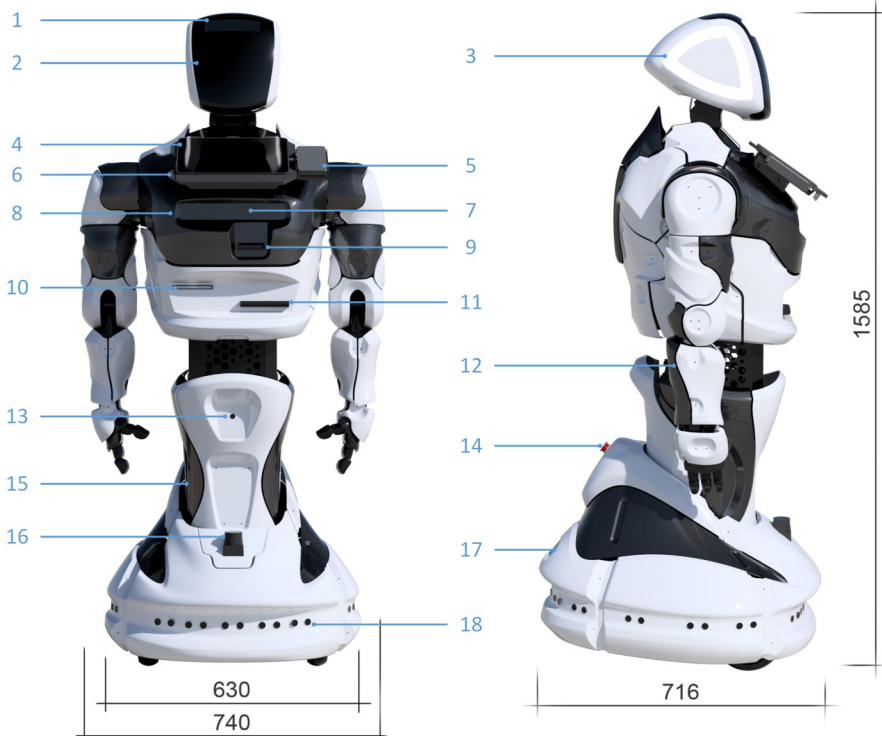

1. Head equipped with microphone, face recognition and detection cameras;
2. RGB matrix displaying facial expressions;
3. Touch sensor system and Segmental RGB LED backlight;
4. Interactive LCD display with touch control;
5. Place for installing a bank terminal\*;
6. Array microphone
7. 3D sensor;
8. Speakers;
9. Card dispenser\*;
10. Receipt printer\*;

11. The photo printer\*;
12. Arms, equipped with touch sensors;
13. Search for charging station camera;
14. Kill switch;
15. Movement platform;
16. Lidar\*
17. Operating ports;
18. A system of sensors to avoid obstacles while moving.

\* Depends on the selected equipment.

# Specifications

No.	Parameter	Description
1	Size of the robot	Minimum: 1485x740x716 (HxWxL), mm Maximum: 1585x2060x716 (HxWxL), mm
2	Size of the charging station	700x650x300 (HxWxL), mm
3	Size of the wardrobe trunk	1620x900x1000 (HxWxL), mm
4	Robot weight	Up to 130 kg*
5	Weight of charging station	10 kg
6	Total weight	Up to 205 kg*
7	Charging time of the robot	Using charging station: up to 10 hours Using power cable: up to 8 hours
8	Battery life	Up to 8 hours
9	Movement speed	0.5 m/s
10	Drive	2 wheels with support wheels
11	Arms	2 manipulators, rotation in 6 degrees of freedom
12	Head rotation	Rotation in 2 degrees of freedom
13	Torso movement	Rotation in 2 degrees of freedom, change of the height of the torso
14	Camera	Face recognition: up to 30 fps at a resolution of 1280x720 Face search: up to 25 fps at a resolution of 1920x1080 Search for a charging station: up to 30 fps at a resolution of 640x480
15	Microphone	Omnidirectional, microphone array*
16	Speakers	25 watts 2 pcs.

No.	Parameter	Description
17	Display	10.1" touchscreen display with a resolution of 1280x800
18	Sensors	Ultrasonic sensors 16 pcs., Infra-red sensors 16 pcs., 3D sensor 1 pc., Touch sensors 4 pcs., Lidar* 1 pcs.
19	Body	Plastic, carbon*
20	Color	White*
21	Color of the face and backlight LEDs	RGB (full-color), segmented headlight
22	Pronunciation of speech modules	Synthesis of speech
23	Random movement	Yes
24	Auto approach to the charging station	Yes
25	Movement of "arms" and "head"	Yes
26	Photo printer*	Yes
27	Printer for printing receipts*	Yes
28	Technological area of implementation of the payment terminal*	Yes
29	Card dispenser*	Yes
30	Service of linguistic base	Yes
31	Analytics service*	Yes
32	Telepresence service*	Yes
33	SIP telephony service*	Yes

\* Depends on the selected equipment. Check with the manufacturer.

## 1.2. Contents of delivery

---

<b>Robot Promobot</b>	1 pc.
<b>Power cord</b>	1 pc.
<b>Specially designed shipping case</b>	1 pc.
<b>Operating Instructions and Data Sheet</b>	1 pc.
<b>Charging station</b>	1 pc.
<b>Kit for photo printer Canon KP-108IN*</b>	1 pc.
<b>Wireless controller</b>	1 pc.

---

## 1.3. Web services

---

- Service of linguistic database and speech modules
- Analytics service\*
- Telepresence service\*
- SIP telephony service\*
- Motion Studio service\*

\* Depends on the selected equipment. Check with the manufacturer.

## 1.4. Application area

---

The main purpose of the robot consultant Promobot:

- Attracting new customers;
- Automation of the process of consultation on products;
- Increasing customer loyalty.

The main functions of Promobot:

- Pronouncing previously loaded speech modules to attract customers;
  - Recognizing, storing and saving the client image and the received data about it;
-



- Pronouncing previously loaded answers to questions about the product and on any other topics;
- Placement of promotional materials;
- Saving and analyzing data in text format;
- Showing previously uploaded photos and videos;
- Chaotic movement within a given space.

The above functionality is provided in the autonomous mode (without human participation), as well as the possibility of remote management and administration. **To perform the above functionality, the robot must have access to the Internet with a speed of at least 4 Mb/sec, ping to [www.google.com](http://www.google.com) should be not more than 50 ms via a dedicated Wi-Fi (2.4 or 5 GHz) channel.**

---

## 1.5. Conventions

---



Attention, important information! This condition is mandatory for execution!



Pay attention to the mains voltage. The power supply must comply with the required parameters.

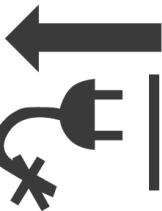

If the power cord is damaged or broken, immediately remove the plug from the socket.

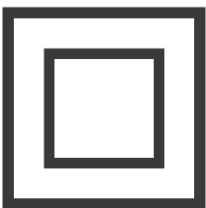

The device has double insulation. This means that all external metal parts are electrically isolated from current-carrying parts. This is done by placing additional insulation between the electrical and mechanical parts.



This function is optional. If you doubt the availability or absence of this function, you can clarify the information with the manufacturer.

---

## 1.6. General safety rules

---



- Please read the safety rules carefully and follow the instructions given in them. Failure to follow the instructions below may result in serious injury from mechanical or electric shock.
- For safety reasons, children under 18 years old, as well as people not familiar with these rules, should not be allowed to operate the robot.
- Use Promobot only for its intended purpose as specified in the user's guide.
- If you do not have the skills to work with electronics, it is strongly recommended that you consult a specialist or an experienced user first.
- Promobot is not intended for use by persons (including children) with reduced physical, sensory or mental abilities, in the absence of experience or knowledge, unless they are controlled or instructed about the use of the device by the person responsible for their safety.

## 1.7. Storage conditions

---



- Remember! You are responsible for the safety in the place of storage of the robot.
- Keep the storage place clean and tidy. Mess can cause a breakdown or injury.
- Do not allow dampness, water vapor, the location of flammable liquids and gases in the storage area.
- To avoid undesirable consequences, do not allow unauthorized persons to access the storage area.

---

## 1.8. Visual control

---



- Before each start of the robot, check the status of the main nodes. Make sure that all robot units are in working order and are able to properly perform the required functions. If any part is damaged, further operation of the robot is unacceptable.
- It is forbidden to use a lock that is not provided by the design (to attach the robot to a static object, block the wheels or lift the robot into the air, etc.).
- The surface of the robot's switching elements must be clean, dry and not greasy.
- If the robot is damaged, contact the service center.

## 1.9. Safety precautions

---



- Comply with all safety regulations.
- When using the Promobot robot, observe the general safety rules for the use of electrical appliances.
- Rotating wheels can cause injury. Do not allow contact with the wheels during rotation.
- Arms of the robot may cause injury during operation. Do not allow contact with the arms of the robot while movement of the robot.

## 1.10. Electrical safety

---



- During operation and after its termination, before servicing, repairing, storing, disconnect the power plug from the socket.
- Monitor the power supply voltage while charging the batteries. The electrical network parameters must correspond to a voltage of 220V at a frequency of 50-60 Hz.
- Voltage above or below 220V can cause battery and charger failure.
- Monitor the charge status of the batteries. It is necessary to produce a full charge at least once a month. Failure to comply with this requirement will void the warranty for the battery.



- Regularly inspect the power cord for damage and wear. The battery should only be charged when the power cord is in perfect condition. The power cord can only be replaced at the service center.

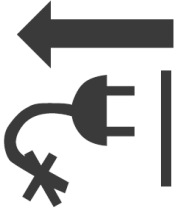

- Caution! If the power cord is damaged or broken, immediately remove the plug from the socket.
- Do not use the power cord to pull its plug from the outlet. Do not step on the power cord. Remove the power cord from the area of the cutting tool. Protect the power cord from heat, oil, sharp edges.
- The mains socket must fully match the power plug of the power tool. It is strongly recommended not to use various adapters, but to install the necessary plug socket. To connect the charging station, use only grounding sockets. Using plug sockets without grounding can cause the robot to fail.
- Use only industry-standard extension cords. The cross-section of the extension cables must not be less than the power cord of the tool. For a length of up to 20 m, use an extension cable with a minimum cross-section of  $1.5 \text{ mm}^2$  or more, and when using from 20 m to 50 m, use an extension cable with a cross section of  $2.5 \text{ mm}^2$ .
- When using an extension cable wound on a drum, pull the cable to its full length. If necessary, consult an electrician.

## 1.11. Technical requirements

---

### 1.11.1. Requirements for the location

The Contractor informs the Customer about the impact of third-party equipment and external factors on the work of the Robot Promobot:



- Promobot is not intended for outdoor use, outdoor use may result in premature failure.
- Sources of bright light and laser in the room where Promobot operates, may be the reason for the impossibility of audiovisual communication.
- Sources of strong noise, loud music in the room where Promobot works, may be the reason for the impossibility of audiovisual communication.
- Thick walls, large columns and other radio opaque obstacles to the propagation of radio frequency frequencies WiFi from the access point to may cause Promobot's temporary inability to work.
- Confident work of WiFi is possible in the line of sight from the set access point at a distance of no more than 50 m.
- In other cases, the range of communication depends on the propagation conditions of radio waves and is determined only by experience.
- The presence of interference on WiFi frequencies, the location in the immediate proximity to the WiFi access point to which Promobot is connected by other operating access may be the reason for the impossibility of the Promobot operation.

### 1.11.2. Requirements for preparing the location for the work of Promobot

The room or location in which Promobot will be used must meet the following requirements:



- Seamless WiFi coverage at frequencies of 802.11n/ac, frequency with guaranteed two-way transmission of at least 4 Mbps on the entire area of the room intended for moving the robot.
- Radio transparency (absence of thick walls, large columns and obstacles in the way of propagation of radio frequencies of WiFi frequencies) from the access point to Promobot.
- Low level of interference at WiFi frequencies (absence of other working access points).
- Presence in the close proximity of the installed equipment (server and access point) of an operational 220V socket with a power of at least 800 W.
- Presence of a place for charging the Promobot near the vertical wall without a skirting board with a floor area of at least 700 x 700 mm in size for one Promobot equipped with a working 220V socket and at least 400 W per Promobot.
- Absence of thresholds and obstacles on the way of the Promobot.
- Absence of stairs and ramps steeper than 10 degrees on the way of the Promobot.
- Absence of sharp differences in the height of the floor in the room.



- Absence of areas with a smooth polished surface on which Promobot wheels can slip on the floor.
- Absence of the places with carpet covering, on which Promobot wheels can slip and slip on the floor.
- Absence of high voltage sources in the close proximity to the robot.
- Absence of sources of strong noise and loud music in the close proximity of the workplace of Promobot.
- Absence in the close proximity of the workplace of Promobot of sources of bright blinding light and directed projectors.
- The average level of illumination in the room should be at least 50 lux.
- The room temperature must be from +10 to +35 degrees Celsius.
- Air humidity in the room must be not more than 70%.



---

## 1.12. Transportation conditions

---



- Transportation of the robot must be carried out only in a specially designed case.
- The robot and other components must be securely fixed inside the case by special transportation carrier. The vertical position of the robot must correspond to the transport marking "top" on the trunk (the robot must be packed upside-down in accordance with the direction of the arrows on the marking). During transportation, the robot must be turned off. Before transporting, make sure that the robot is de-energized by moving the power button to the "off" position.
- Before transporting, make sure that there are no foreign objects inside of the compartment. The presence of foreign objects can damage the robot's parts.
- During transportation, the actuator should be in the lowest position, and the robot body is fixed in a fully rectified state.
- During transportation, the robot box is considered to be a fragile freight. Ensure adequate transport and storage conditions for the entire transportation period.

## 1.13. Navigation conditions

---

### 1.13.1. Requirements for floor covering

Floor. The robot moves with the help of 2 driving motor-wheels and 2 steering wheels. Wheels do not have a cushioning system. Steering wheels are solid, of small diameter. The weight of the robot is 130 kg.

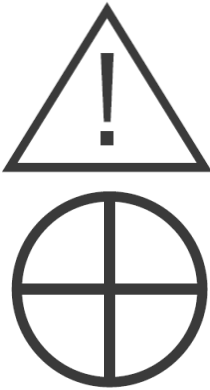

- In the area of automatic movements of the robot, the floor should be flat, horizontal, have no thresholds, joints, hatches.
- The floor covering should be solid and the same on the entire area - the robot cannot move on soft surfaces (carpet, soft linoleum).
- It is unacceptable to use the moving robot where there are differences in height on the floor, such as steps, thresholds.
- Rugs and other movable floor coverings are unacceptable.
- It is undesirable to use the robot in rooms with unevenly laid tiles and unevenly filled joints between the tiles.

### 1.13.2. Requirements for walls and interior

The robot's navigation system is based on the use of a lidar — a laser scanner located at the bottom of the robot.

- Surfaces should not completely reflect, pass, or absorb light. It is unacceptable to have mirrors,



glasses, dark mat surfaces at a height of 40 cm from the floor around the perimeter of the room.

- The distance between the walls and objects in places where the robot passes must be at least 1.7 meters.



- Do not rearrange large objects (sofas, cabinets) in the room after building a map for the robot. Rearrangement of the area requires the change of the map for the robot.
- It is undesirable to have objects on high legs (for example, tables and chairs) in the area of movement of the robot.

### 1.13.3. Requirements for placing the charging station



- The charging station must be located so that the robot can reach it from anywhere in the room.

- The distance from the charging station to the walls and objects in front of it must be at least 3 meters. The distance from the charging station to the walls and objects to the right and left of it should be at least 1 meter.

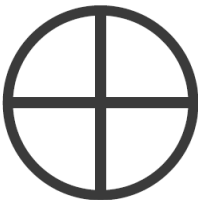

- The 220V power outlet should be located not more than 50 cm from the charging station.
- It is unacceptable to block the robot's passage to the charging station.

## 2. Arrangement and components

### 2.1. Head

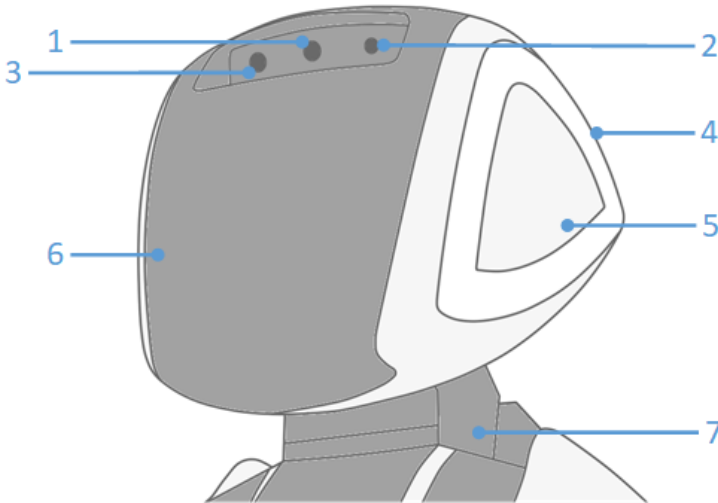

Fig.2.1.

1. The robot uses a **face recognition camera** to perform human face recognition in the interaction mode, and it is possible to store information about it in the database (with the consent of the user).
2. In standby mode, the robot can use the **microphone** for speech recognition. It is an alternative to a microphone array, for example, if the robot configuration does not support its installation.
3. The robot uses a **face detection camera** in standby mode to search for people in front of it, the camera has a wide viewing angle, so that the face detection area covers large areas.
4. **RGB backlight** changes depending on the current robot status.  
Backlight colors:



White color — standard backlight mode.



Green color — implies the operation of speech synthesis.



Orange color — implies the operation of speech recognition.



Blue color — implies the blocking of movements by the robot sensors.



Yellow color — implies the operation of touch sensors.

5. **Touch sensors** detect the touch of a person, which is accompanied by the reaction of the robot.
6. **RGB matrix** performs the function of a face, and, depending on the information received, displays various animations of "emotions".
7. **The moving neck** is responsible for the rotation of the head in 2 planes.

---

### It is forbidden to:



- Touch the camera;
- Allow moisture and foreign objects to enter the openings of the microphones and the video camera;
- Try to turn the robot's head using force;
- Try to troubleshoot yourself.

## 2.2. Torso

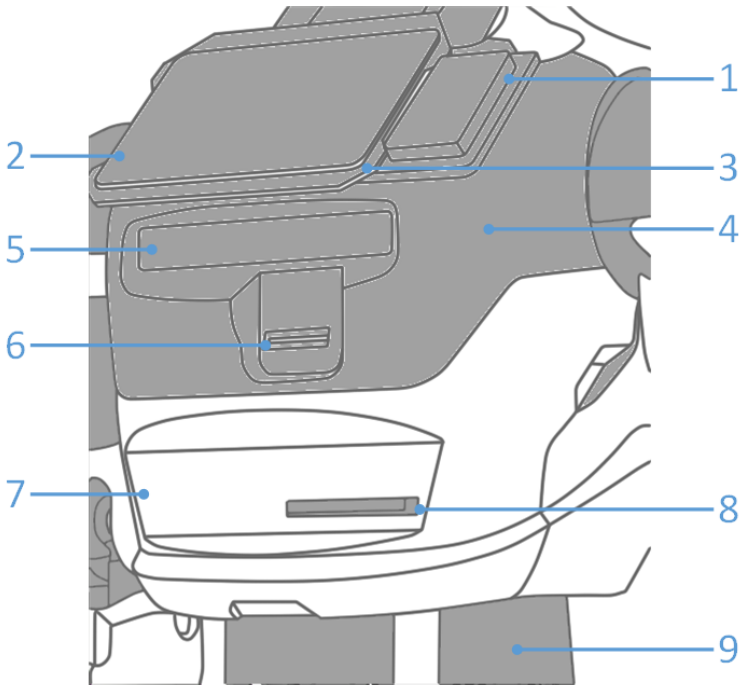

Fig.2.2.

1. **Place for installing a bank terminal**, allowing the robot to accept payment by bank cards. The terminal is installed separately.
2. **Interactive display** serves to display information about the operation of the robot and is equipped with a touchscreen sensor, which allows you to communicate with the robot by touch.
3. **The microphone array** is used together with the face recognition camera to position the user with whom the robot is communicating, as well as to improve the speech recognition system.
4. **The speakers** are used to synthesize the robot's speech.
5. **The 3D sensor** scans the space in front of the robot, identifying the presence of obstacles or people.

6. **The card dispenser** allows to use the robot for handing out plastic cards in an automatic mode.
  7. **The receipt printer** uses special thermal paper to print receipts or coupons.
  8. **The photo printer** is used to print images, such as photos or promotional materials, using the photo paper.
  9. **Moving torso** supports rotation in 2 planes.
- 

### It is forbidden to:



- Allow moisture and foreign objects to enter the holes of the speakers, receipt and photo printers, as well as to spill moisture on the touchscreen display;
- Touch the display with dirty, wet hands;
- Touch the 3D sensor, allow it to become dirty;
- Trying to get yourself under the robot's body (holes under the torso, on the neck, etc.) in ways not provided for by the design, and using physical force.

---

## 2.3. Hand-operated manipulators

---

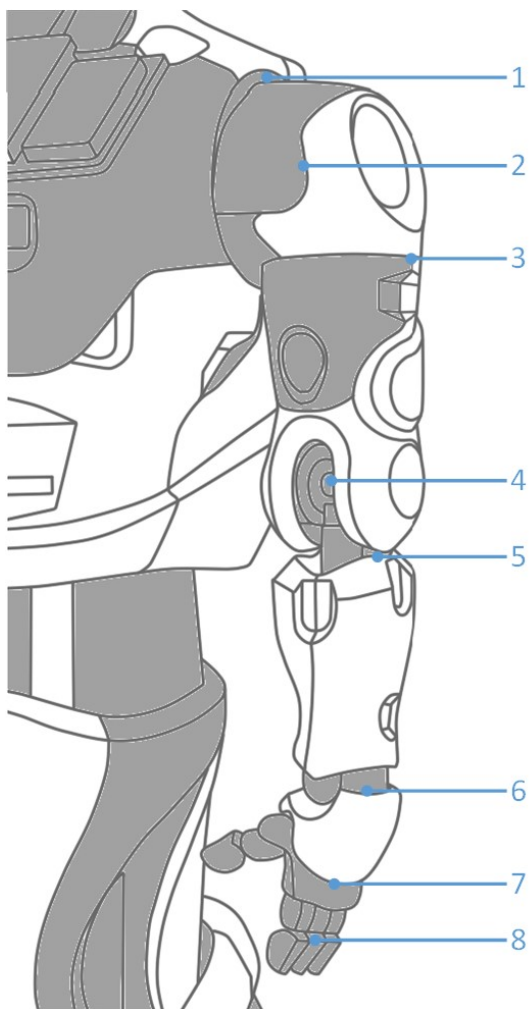

Fig.2.3.

Arms are designed for gesticulation of the robot during communication. The 6 degrees of freedom allow you to simulate the movements of human arms. The hands are equipped with a touch sensor to determine handshakes and other actions.



### Moving joints:

1. Rotating shoulder joint
2. Moving shoulder joint
3. Rotating elbow joint
4. Moving elbow joint
5. Moving hand joint
6. Moving wrist joint
7. Touch sensor
8. Hand-manipulator



In order to avoid undesirable consequences, the operation of the lower front sensors of the robot blocks the movement of its hands until the obstacle in front of the sensors disappears.

---

### **It is forbidden to:**



- Allow moisture and foreign objects to enter the openings of the mobile elements of the arm;
- Allow excessive impact on the hand;
- Try to move joints on your own.

## 2.4. Movement platform

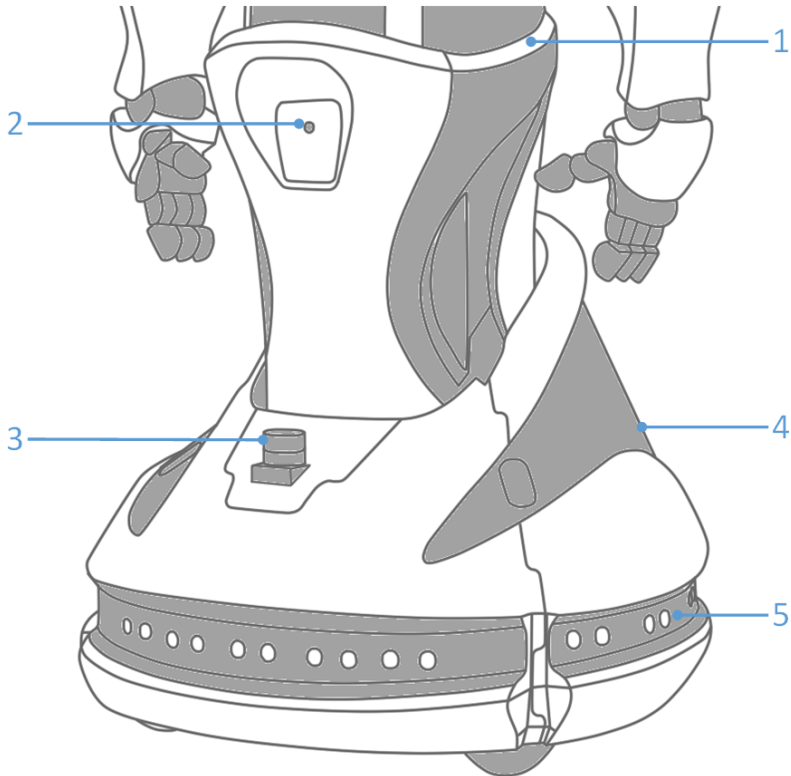

Fig.2.4.

1. During the use, it is possible to adjust the height of the robot using **an actuator**. After the interaction begins, the robot will automatically adjust the height to the height of the person.
2. **The charging station search camera** searches for the identification mark of the charging station for the automatic approach and the connection of the robot to the charging station.
3. **Lidar** is used for navigation indoors. Lidar is an analogue of the sonar, scanning the space in front of the robot using laser beams.

4. **The movement platform** is equipped with two driving wheels and support wheels.
5. **Around the perimeter of Promobot, 16 obstacle detection sensors** are installed, which are a combined ultrasonic and infrared sensor. The sensors are equipped with LED indication:
  - Blue color — ultrasonic sensor was activated;
  - Green — infrared sensor was activated;
  - Turquoise color — ultrasonic and infrared sensors were activated;
  - No color — no sensor activation.

---

### It is forbidden to:



- Allow moisture and foreign objects (especially people's hands) to enter the openings of the moving elements of the elevator;
- Allow the camera or sensors to become dirty, block them with foreign objects;
- Touch the wheels while driving;
- Allow objects that are capable of hindering their rotation to hit the wheels;
- Allow moisture to enter the wheelbase of the robot.

---

## 2.5. Operational ports

---

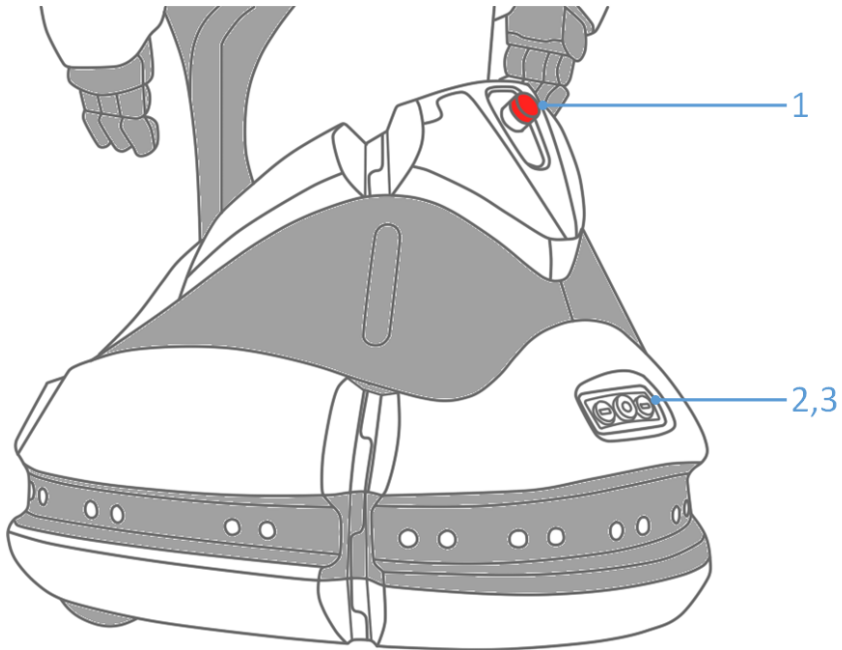

Fig.2.5.

1. **The kill switch** allows you to instantly power off all robot drives in the event of an emergency.
2. To charge the battery manually, the battery **charging port** is used. You need to install a specialized connector in it, which is included in the delivery.
3. **USB port** is used to upload files to the robot, as well as upload photos, video or other data from the robot.

---

### It is forbidden to:

- Allow moisture to enter the ports.



## 3. Operation

---

### 3.1. Safety measures before commissioning

---

Before commissioning, visually evaluate:

- Condition of all housing components;
- Condition of arms and head;
- Condition of the front RGB matrix and interactive display;
- The absence of foreign objects that can interfere with the movement of the robot.

---

### 3.2. Commissioning

---

Promobot robots are delivered in a special transportation trunk. At the time of transportation, the robot is secured inside the casing by a special bracket. To remove the robot from the box, follow these steps:

1. Place the trunk in a vertical position in accordance with the shipping markings.
2. Detach the cover for time of unloading using the latches on the sides of the cover.
3. Remove the retaining bracket by unscrewing the bolts securing it to the back of the case.
4. Remove the contents of the case and free the robot from the cushioning lodgment.
5. Using special screws, detach the holding bracket from the robot, as shown in the figure 3.1.

- Screws can be screwed into the sides of the bracket. Remove the lodgment and bracket back into the trunk and put the cover on. **Keep the components of the box, as they may be required for future transportation of the robot.**

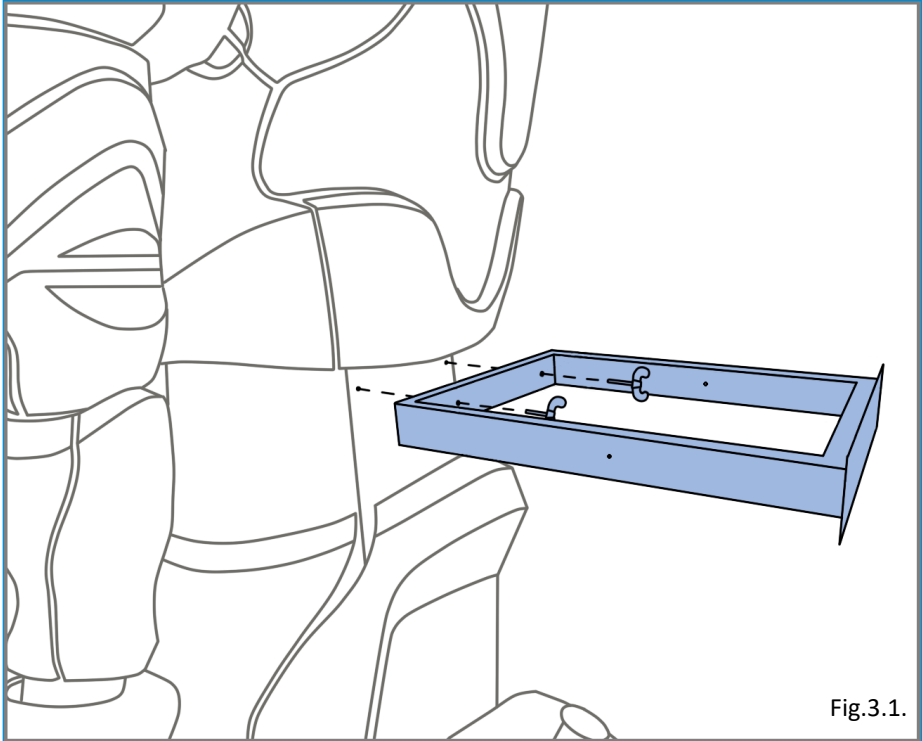

Fig.3.1.

To switch on Promobot one need to make sure that the **power break switch (3)** is in the "ON" position, then press the **power button (2)**, which is in the lower part of the torso of the robot at the left side of the body.

In case of transportation of the robot at negative temperatures, before switching on, be sure to let the robot warm up to a temperature at least +10°C.

After pressing the power button, all robot systems will start loading, which will be reflected on the screen (Fig.3.3).

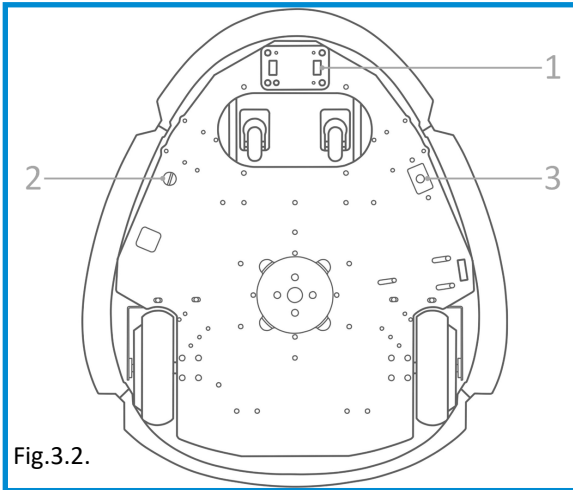

Fig.3.2.

After starting, the start screen appears on the LCD screen(Fig.3.4)

Calibration of the moving parts will begins simultaneously with the start of the robot. Calibration is necessary for correct execution of movements and will be performed every time after the robot is completely disconnected or the drive power is turned off using the emergency power-off button.

completely disconnected or the drive power is turned off using the emergency power-off button.

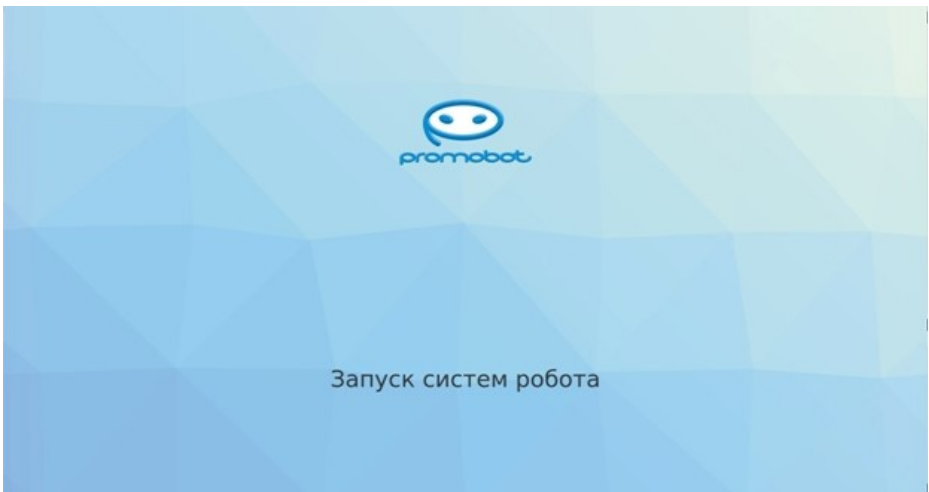

Fig.3.3.

**Attention! For correct calibration, the actuators must be set to the initial position, and the movements of the robot in the process should not be restricted to foreign objects. Be careful, calibration starts automatically!**

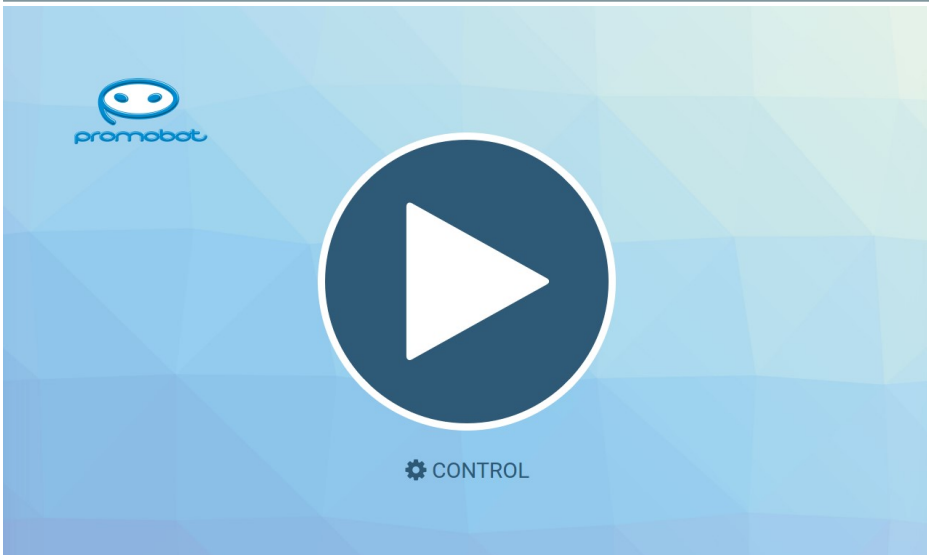

Fig.3.4.

At the top of the Promobot screen is the status bar (Fig.3.5).

The main elements of the panel are:

1. Robot ID.
2. CPU load state, expressed as a percentage.
3. Coefficient of popularity of the robot (the number of interactions divided by 100).
4. Percentage of correct answers.
5. Status of the data base replication
6. Status of the connection to the Wi-Fi network.
7. The state of battery charge of the robot, expressed in percentage. A lightning bolt icon instead of percent means that the robot's battery is currently charging.



Fig.3.5.



The state of the data base replication:

- ✓ Success
- ✗ Fail
- ↻ In progress
- ⊛ Undefined

The state of the battery charge:

- ▢ 0-20%
- ▣ 20-40%
- ▤ 40-60%
- ▥ 60-80%
- ▦ 80-100%
- ⚡ Charging

By pressing on **"Control"**, you can go to the Promobot control menu:

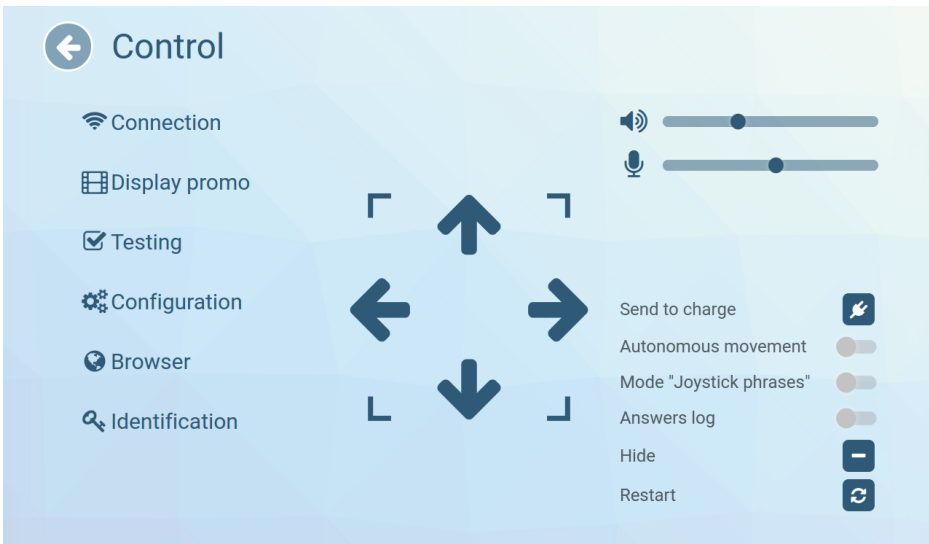

Fig.3.6.

The "**Control**" menu provides quick access to the main control elements, which include:

- Volume controls for the speakers and microphone sensitivity. The value affects the system parameters and is stored until the robot turns off. When enabled, the parameter values are downloaded from the database, while changing the value directly in the database will be applied only after the next time the robot is started. Similarly, the regulators on the robot's main screen work. (you can adjust the constant volume and microphone sensitivity in the "System" section of the Promobot settings menu).
- The button for starting the automatic approach to the charging station.
- Special mode switches. The switch "**Automatic mode**" is responsible for activating the automatic robot movement mode. Switch "**Controller activated phrases**" switches on a controller activated phrases mode, in which the robot uses pre-uploaded phrases, activated from the controller. The "**Answer Log**" switch is responsible for displaying the system interaction log on the main screen, which displays the recognized phrases and phrases received from the database in response.
- Buttons for hiding and rebooting the user interface.

Also, this menu contains several basic submenus:

"**Connection**" – contains information about available networks for connecting to a Wi-Fi network, as well as the signal strength of the networks (Fig.3.7).

It is recommended to choose a network with the maximum signal level. When connected to a network, the ping and Wi-Fi signal strength can be found by pressing "Connection information" at the bottom of the screen. The **ping value must be above 0 and below 50** for Promobot to function correctly. The ping value of 0 means that



Fig.3.7.

there is no Internet connection. **The robot does not connect to hidden networks.** When the connection information button is tapped, the area with the main connection parameters appears.

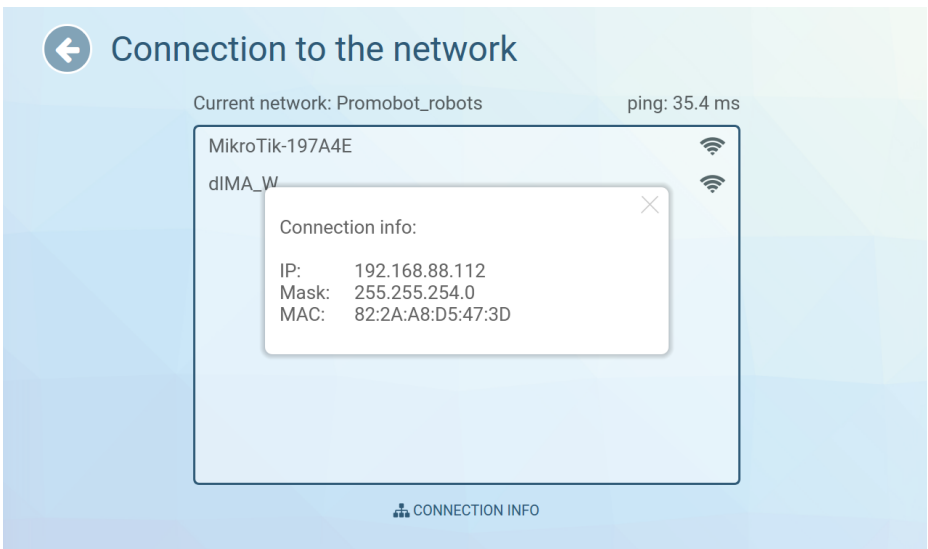

Fig.3.8.



**Important!** Before connecting, make sure that the ports shown in the table are open in the router's settings:

No.	Remote Resources	Port	Protocol	Purpose
1	google.com	80, 443	TCP/UDP	Speech Recognition
2	pb2.icmm.ru	80, 443	TCP/UDP	Web-interface of linguistic base
3	195.69.156.234	22105	TCP	VPN connection for remote monitoring and configuration
4	update.promo-bot.ru	80, 443	TCP/UDP	Update software
5	teleop.promo-bot.ru	80, 443, 8080	TCP/UDP	Telepresence service
6	46.4.94.90	80, 443	TCP/UDP	STUN/TURN for telepresence
7	archive.ubuntu.com	80	TCP/UDP	Update software
8	ru.archive.ubuntu.com	80	TCP/UDP	Update software
9	security.ubuntu.com	80	TCP/UDP	Update software
10	archive.canonical.com	80	TCP/UDP	Update software
11	extras.ubuntu.com	80	TCP/UDP	Update software
12	ppa.launchpad.net	80	TCP/UDP	Update software
13	dl.google.com	80	TCP/UDP	Update software
14	apt.postgresql.org	80	TCP/UDP	Update software
15	repo.yandex.ru	80	TCP/UDP	Update software
16	repo.zabbix.com	80	TCP/UDP	Update software

Close the window with information about the connection by pressing on the cross in its upper right corner.

To connect to a network, select it by pressing the list of available networks. In the window that opens, enter the password from the network and press the "OK" button.

If the connection is successful, the name of the network to which the connection is made will appear opposite the "Current net-

work:" item. To check the connection status, you can use the browser, go back to the "Control" window and select "Browser", then open any page (If the page is loaded, an Internet connection is available). While the "Connect to the network" menu is open, the connection icon on the status bar can periodically show that the network is not connected (the current network connection can be defined in the "Current network:" field), since this is when the available connections are searched.

**"Show promo"** – contains the upload interface for Promobot promotional materials and photo frames. Images in the \*.jpg format are displayed correctly on the Promobot screen. The display of files with a different extension is not guaranteed by the manufacturer. The resolution of the slide show window is 1180x568.

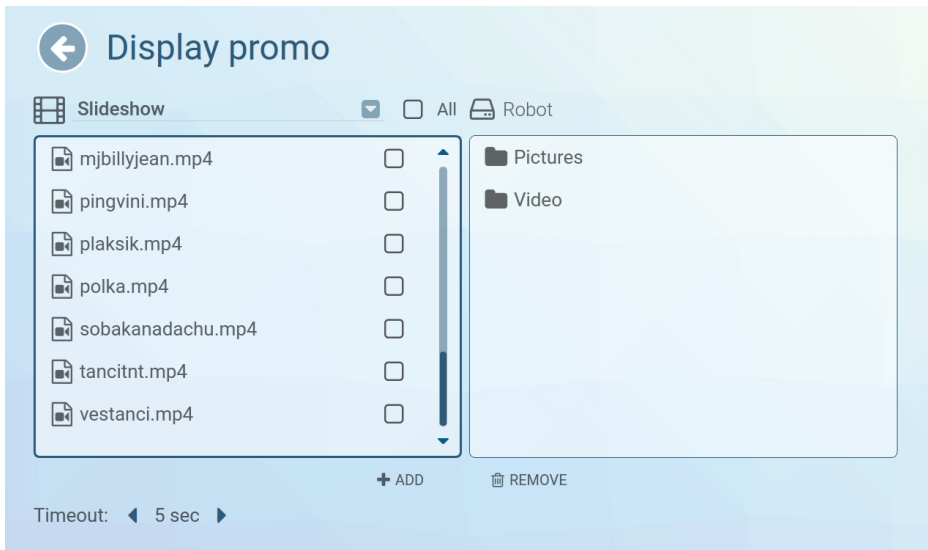

Fig.3.9.

To add a new promotional material, using the file manager on the right side of the screen, select the necessary video files and/or images and press "add" at the bottom of the screen. Confirm the action by pressing on the "Yes" button (Fig.3.10).



Fig.3.10.

After confirmation, the added file will be displayed on the left side of the screen.



Fig.3.11.

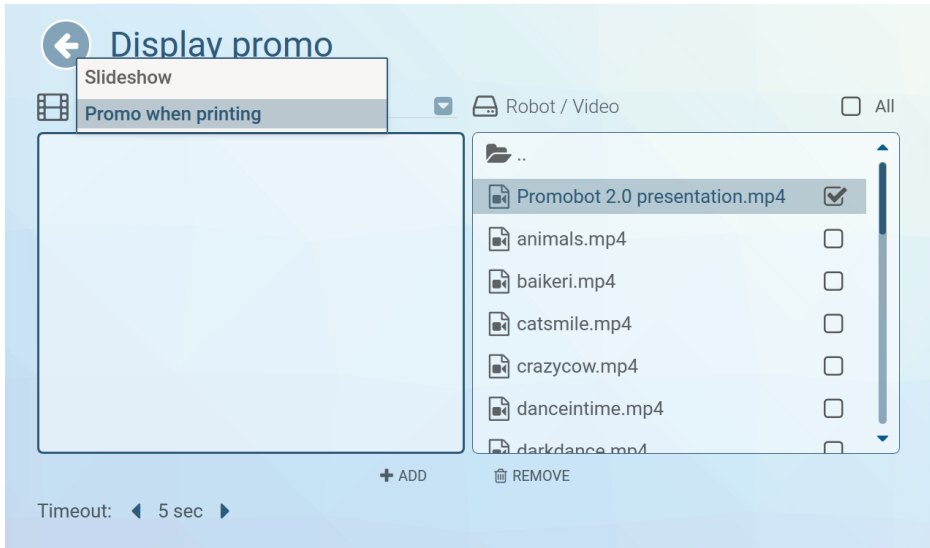

Fig.3.12.

To delete a promotional material from the robot, select the file to be deleted on the left side of the screen and press "delete" at the bottom of the screen, then confirm the deletion of the file (Fig.3.11).

In the slideshow you can create a list of photos and video files that will be displayed on the robot's display constantly, one by one, in alphabetical order. If you decide to add video files to the slideshow, we recommend add them without sound, because otherwise the sound of the video will prevent the robot from correctly recognizing the speech. The frame rate can be set by the timeout parameter (time in seconds). To switch between "Promo when printing" and "Slideshow", use the drop-down list at the top left of the screen (Fig.3.12).

**"Testing"** - contains a test mode interface, which allows you to test the robots' main systems. **Full testing functionality is available only after the robot is started** (for more details, see Section 3.3 for more details on the launch process).



Fig.3.13.

Using the test screen, you can check the operation of moving parts of the robot (arms, head), the image from the cameras, the operation of the microphone and speakers, and ask for the status of installed equipment.

"**Settings**" – contains a menu of settings, for convenience, divided into several sections:

- Section "**System**" – contains the basic settings of the Promobot system.
- Section "**Applications**" – contains settings and information installed on Promobot applications and widgets.
- The "**Face Recognition**" section contains the management of the database and the settings of the Promobot face recognition system. **Attention! This section is intended for experienced users, it is strongly recommended not to change the face recognition parameters yourself.**



- Section "**Navigation**" – contains parameters of the navigation system of Promobot. **Attention! This section is intended for advanced users, we strongly do not recommend to changing the navigation parameters yourself.**
- Section "**Linguistic database**" – contains settings for the use of the linguistic base of Promobot.
- Section "**Language settings**" – contains the settings used by Promobot language packets for speech recognition and synthesis.
- Section "**Internet Services**" – contains the settings of Internet services used by Promobot, for example, the mail client.
- Section "**Update**" – contains tools to check for updates to Promobot and download them.

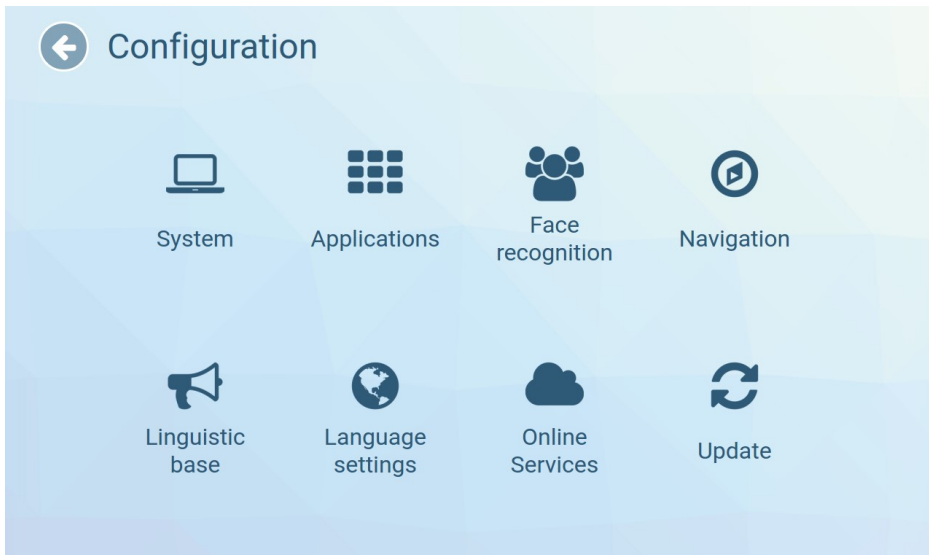

Fig.3.14.

"**Upload promo**" – if you select this item, you can upload promo materials from a USB drive to the file system of the robot. **This section is only available when a USB drive is connected.** To copy a new promotional material from a USB drive through the file manager on

the left side of the screen (External device), select the necessary video files and/or images, open the folder you want to copy to in the right part (Robot) and press "copy" at the bottom of the screen, after which the added file will be displayed on the right side. To delete promo materials from the robot, select the file to be deleted on the right or left side of the screen and click "delete" at the bottom of the screen. **Similarly, you can delete other files that are on the robot. To upload photo frames, use images with a resolution of 604x405,** the background should be an alpha channel (transparent layer). **The recommended resolution of images and videos for the slide show is 1180x568. Recommended promo resolution in the photo app is 1260x665.** The "Documents" type is used for files sent via e-mail, the robot interface does not contain viewing tools for files of this type.

Promobot supports the following file types:

File type	Supported file resolution
Videos	*.mp4, *.avi, *.mkv
Images	*.jpg, *.jpeg, *.png, *.gif
Audio	*.mp3
Documents	*.pdf, *.doc, *.docx, *.xls, *.xlsx, *.ppt, *.pptx, *.txt, *.csv
Photo borders	*.png

**"Browser"** – opens a browser window (Fig.3.15).

On the "Browser" tab you can access any sites on the Internet, and, if necessary, get authorization to connect to a Wi-Fi network. By default, the homepage of Promobot is installed.

**"Identification"** – by selecting this item, you can change the access password to the "Manage" menu from the user interface. To change the password, enter a new password, and then enter the password again to confirm the correct entry.

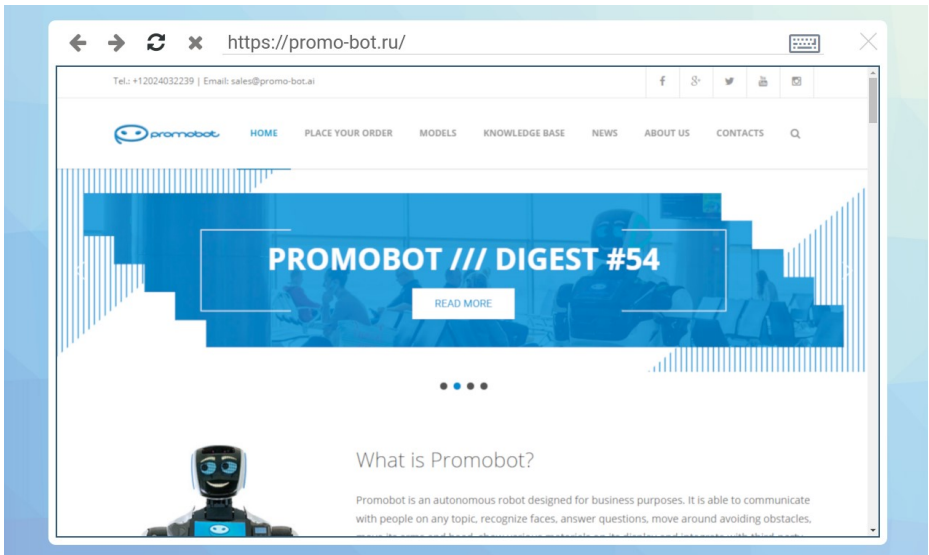

Fig.3.15.

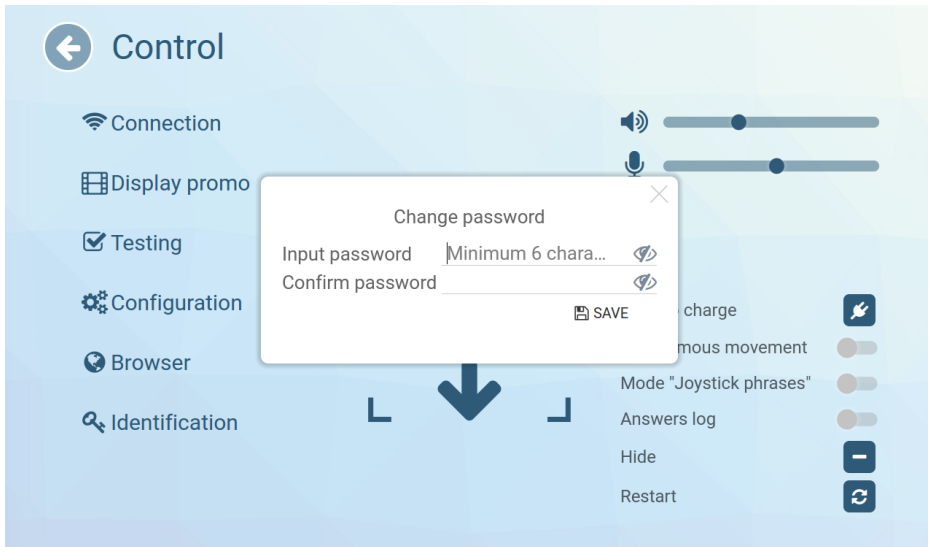

Fig.3.16.

## 3.3. Launch of Promobot

To launch Promobot tap the "Start" button on the start screen:

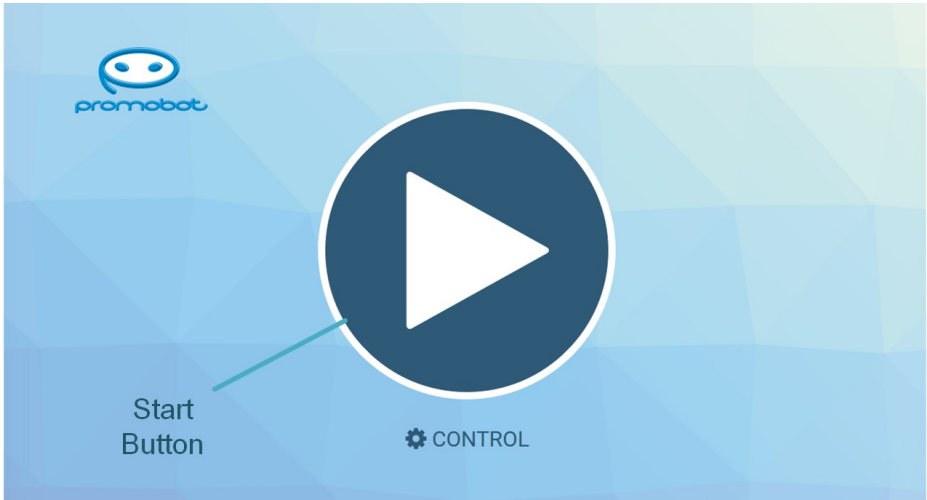

Fig.3.17.

After launch, the user interface will be displayed:



Fig.3.18.

Pressing the animated "Eye" button in the upper right corner opens the image viewing interface from the camera:

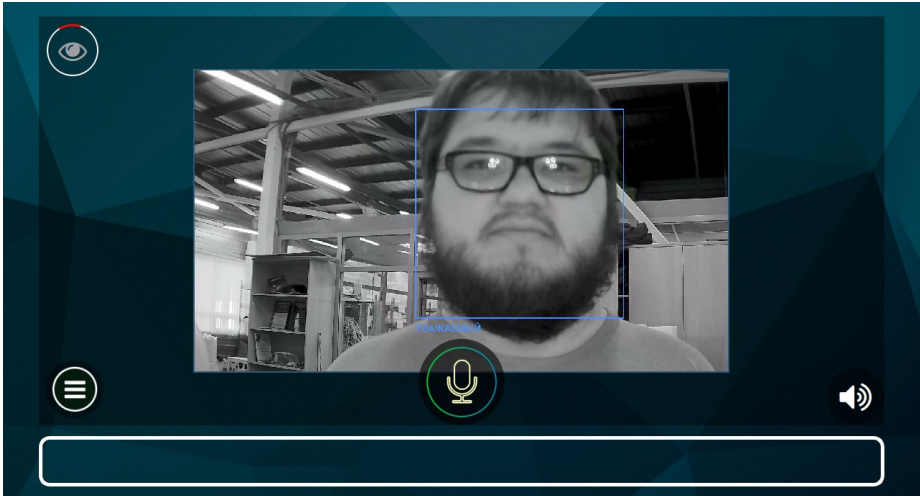

Fig.3.19.

Pressing the "Sound" button in the lower right corner allows temporarily (before reloading) to change the settings of the robot's speech synthesis and the volume of the robot's speech.

Pressing the "Application Menu" button opens the Promobot application and widget bar:

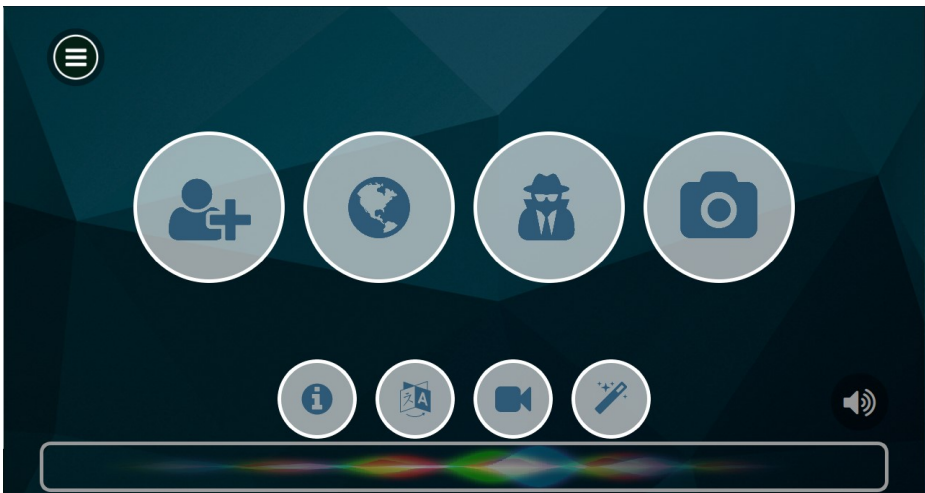

Fig.3.20.

At any time from the main screen, you can go to the "Control" menu to control the robot or change the settings. To activate the menu, you must press four times in the area indicated in the image below:



Fig.3.21.

When the service menu is activated, an access window appears in which you will be asked to enter a password. The default password for all robots is **123456**. It can be changed after entering the menu.

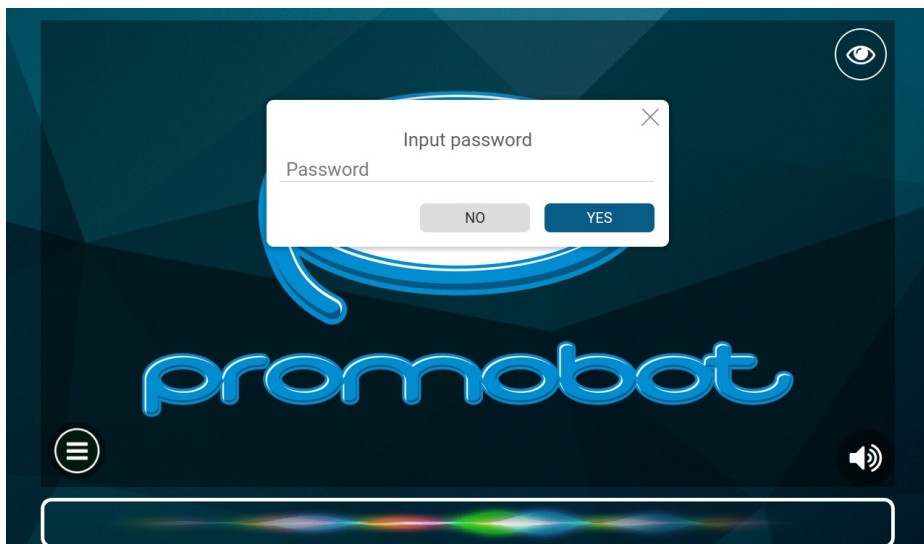

Fig.3.22.

## 3.4. The use of Controller

To control the robot, use the supplied paired controller (the number on the controller corresponds to the robot number). In case of breakdown or loss of the controller, please contact the service center.

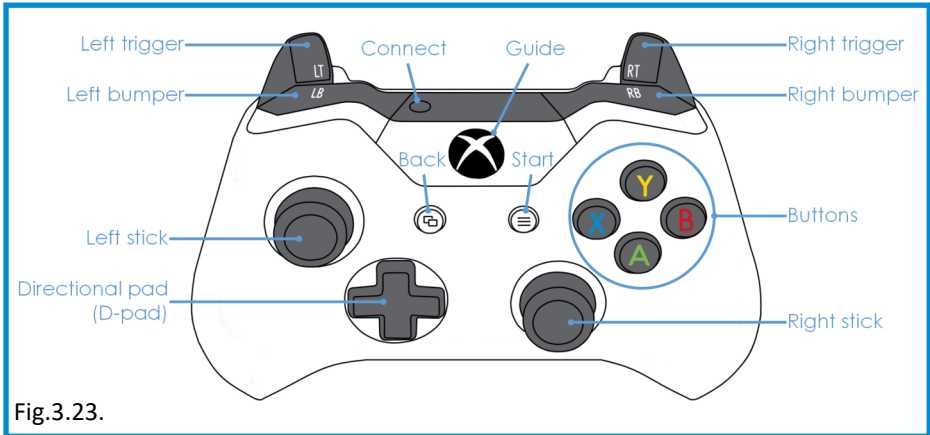

Fig.3.23.

### Combinations for robot control:

Combination	Description
Back + Start	Switching the automatic movement mode
Back + Y	Controller activated phrases mode
A + Left stick	Go fast
B + Left stick	Go normal
A / B + Directional pad	Head control (when moving up and down, the actuator also works)
X + Left bumper	Increase the speaker volume by 5%
X + Left trigger	Lower the speaker volume by 5%
X + Right bumper	Increase microphone sensitivity by 2%
X + Right Trigger	Lower the microphone sensitivity by 2%
Only in the phrase controller activated phrases mode	
Y + Right Trigger	Next phrase
Y + Right bumper	Previous Phrase

## 3.5. End of work. Charging station

In the event of a battery discharge, the robot will notify you. (A facial expression will change on its face, and a corresponding voice notification will occur). The robot provides an automatic access to the charging station. For the correct work of this function, the **robot must be from 4 to 6 m radius of the charging station** to which it can approach meeting **no obstacles on its way** (the identification mark of the charging station must be in the line of sight of the charging station search camera), objects near the charging station can trigger the ultrasonic sensors, avoid placing the charging station in cluttered places and narrow spaces.

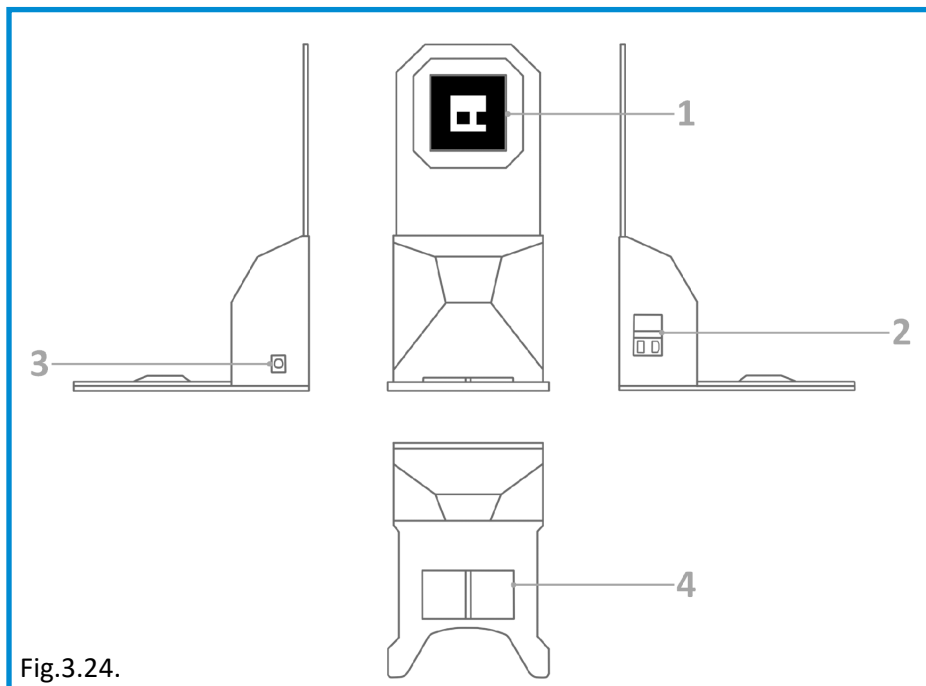

Fig.3.24.

1. QR identification mark of the charging station;
2. Connector to power the station;
3. Connector to charge robot;
4. Charging connection.



If necessary, the robot can carry out automatic recharging on a schedule, you can enable this mode in the settings.

In the event that the use of automatic charging is impossible or difficult, the battery can be charged using the power port on the back of the robot.

## 3.6. Transportation

To carry out safe transportation of the robot, it is necessary to de-energize it by switching the power break switch to the "off" position. This switch is located at the bottom of the torso of the robot under the body on the left side. For safe transportation, use a special trunk, equipped with a lodgment and a bracket. Before transporting, secure the robot in the trunk with a bracket.

1. Contacts for connection to the charging station;
2. Power button;
3. Fuse button.

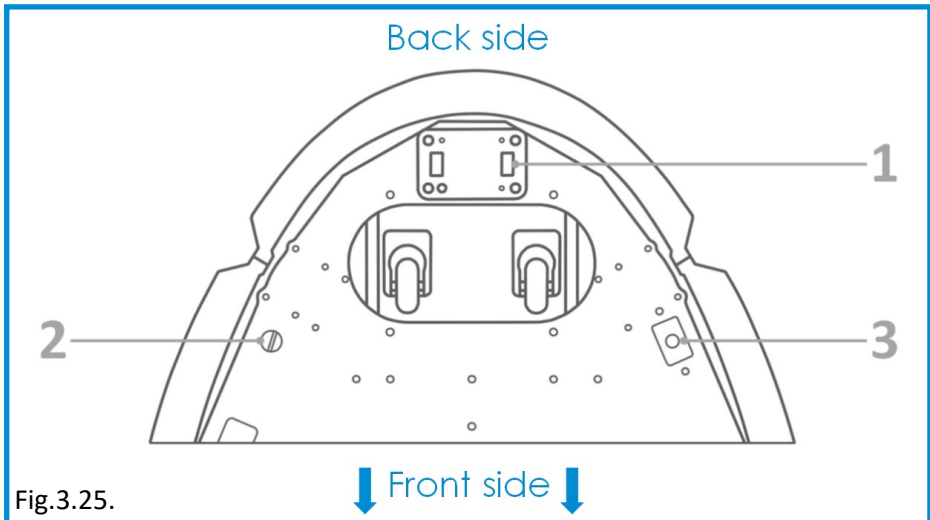

Fig.3.25.

## 3.7. Printing photos

---



**This function is optional. If you doubt the availability or absence of this function, you can clarify this information from the manufacturer.**

Photo printing is done on 100x148 mm (4x6 ") glossy photo paper, for example the included Canon KP-108IN (108 sheets of photo paper + 2 toner cartridges). Use paper that is compatible only with the Canon Selphy CP1000 printer. Using incompatible paper will result in a loss of warranty for the printer.

**Before carrying out the maintenance robot, read the user's guide to the Canon Selphy CP1000 printer.**

### Printing process

The printer allows you to print color photographs or postcards (depends on the paper selected). **During the printing process, photos/postcards can appear several times in the photo-exit hole on the front of the robot's torso, wait for the printing process to finish.**

**If the paper cassette is empty at the time of printing, an error message will appear and the printing process will be canceled.**

### Adding paper

Carefully remove the paper cassette. Open the cassette cover and load the photo paper inside with the glossy side up (**no more than 18 sheets**). **Make sure to remove the protective cover!** Then close the cassette until it clicks and set it back to its original position. **Make sure the cassette is installed correctly!**

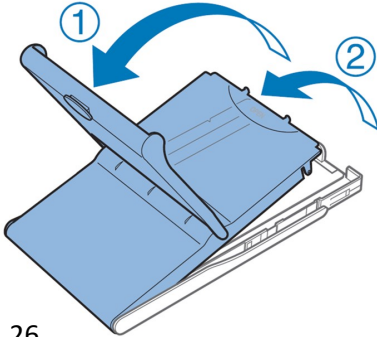

Fig.3.26.

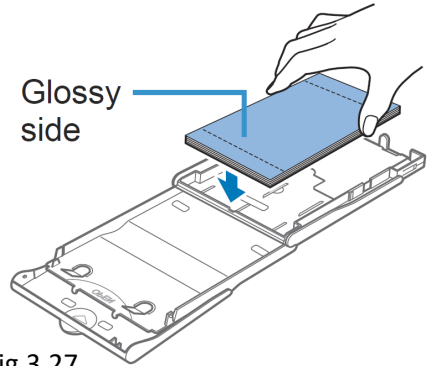

Fig.3.27.

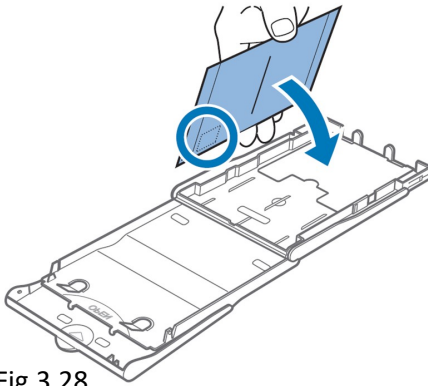

Fig.3.28.

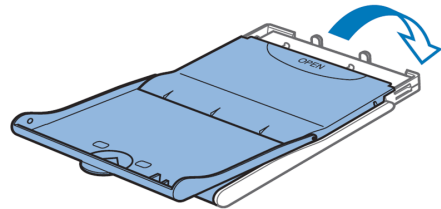

Fig.3.29.

## Replacing Toner Cartridges

- Remove the service compartment of the robot by pressing the lock lever under the bottom of the back cover and pulling the cover as shown in Figure 3.26.
- The printer is located on the left side of the back cover, the position of the printer is indicated in Figure 3.27.
- To remove the cartridge, press the release lever shown in Figure 3.28. to replace the cartridge. A new cartridge must be installed before the latch clicks. After the work is completed, return the robot's service compartment to its original position by sliding it into the robot. **Make sure the cover is securely fastened.**

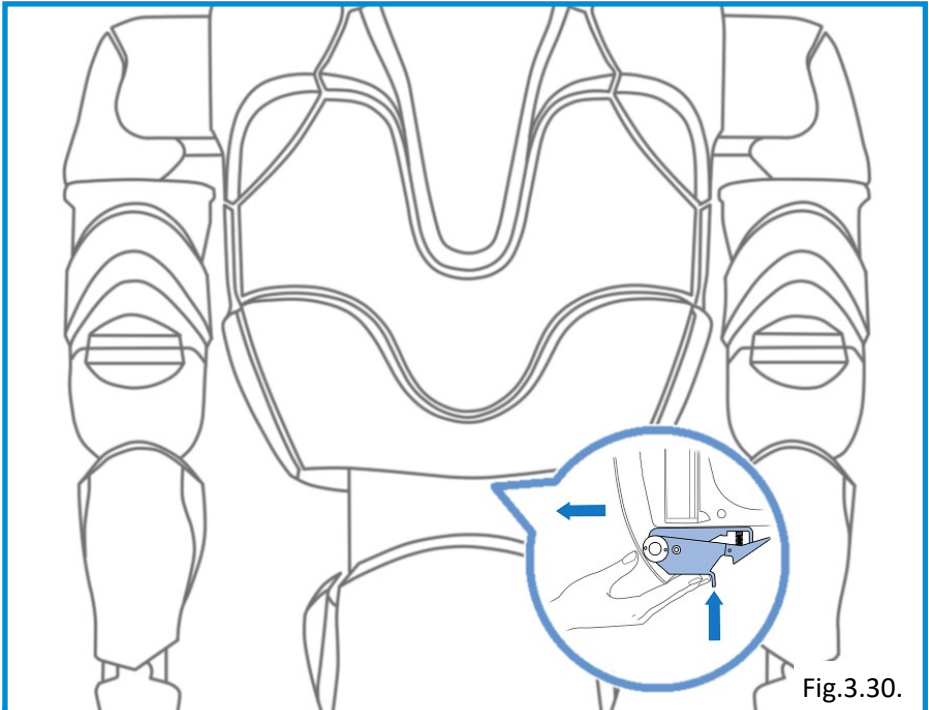

Fig.3.30.

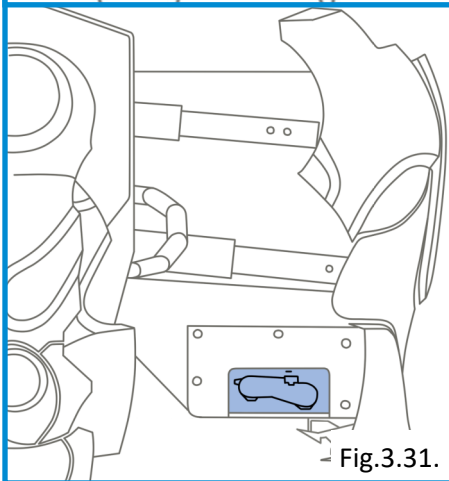

Fig.3.31.

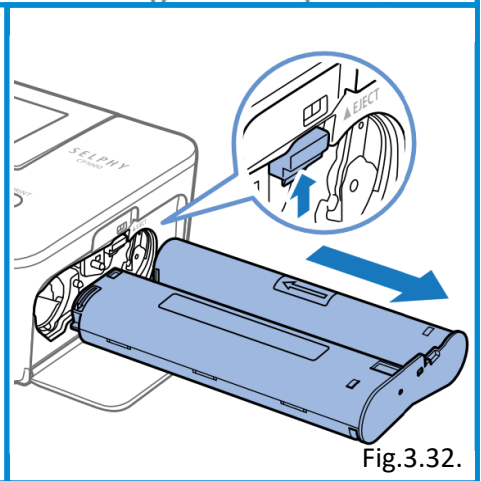

Fig.3.32.

## 3.8. Printing receipts



This function is optional. If you doubt the availability or absence of this function, you can clarify this information from the manufacturer.

Printing receipts is carried out on thermal paper with a width of 80/82.5 mm and a density of 60 to 120 g/m<sup>2</sup>.

**Before carrying out the maintenance of the robot, review the user manual for the Thermal printer Custom TG2480.**

### Service

Remove the service compartment of the robot by pressing the lock lever under the bottom of the back cover and pulling the cover as shown in Figure 3.29.

The printer is located on the right side of the back cover, the position of the receipt printer is indicated in Figure 3.30.

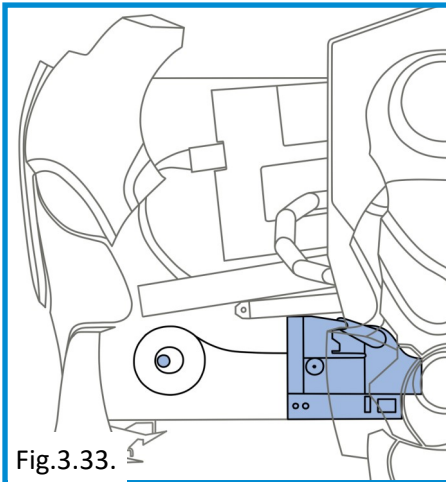

Fig.3.33.

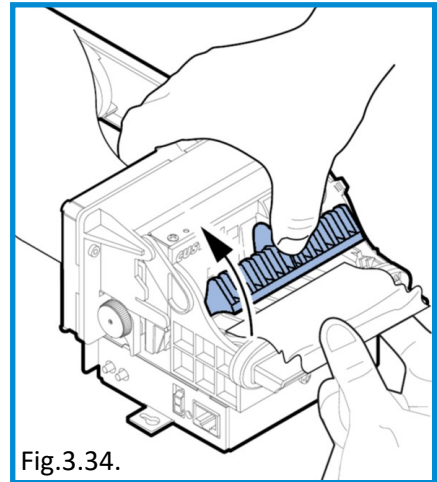
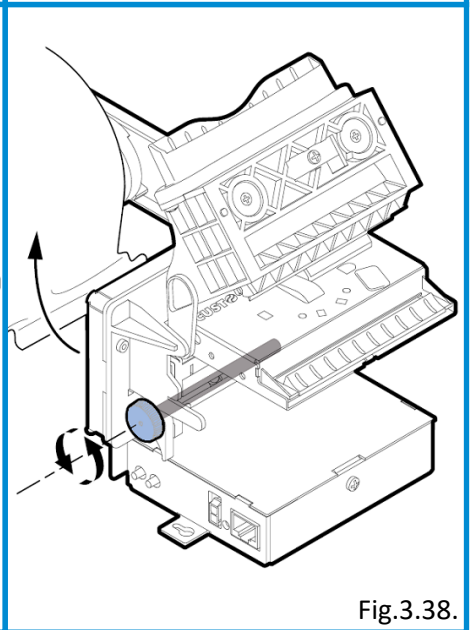
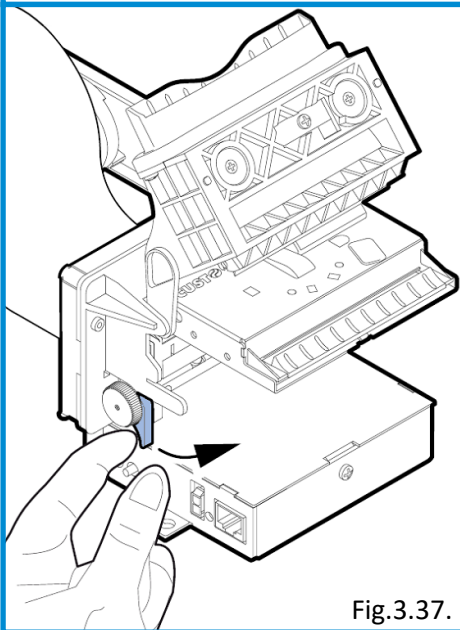
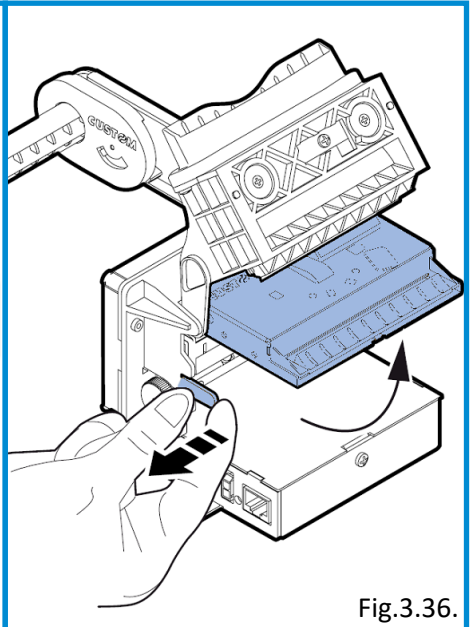
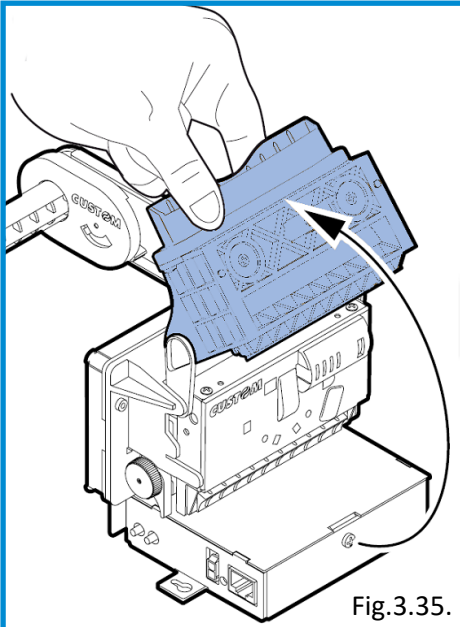

Fig.3.34.



## Paper Jam

Follow these steps to get rid of paper jams:

- Raise the control flap and remove the pieces of paper (Fig.3.31).
- Turn the paper dispenser unit to the maximum open position (Fig.3.32).
- Slightly bend the clamps of the slicing unit and turn the block upwards (Fig.3.33).
- Raise the scroll roller release lever (Fig.3.34).
- Scroll the roller counterclockwise to remove the paper (Fig.3.35).

## Replacement of a roll with paper

To replace the receipt printer paper, follow these steps:

- Remove the used roll with paper.
- Place a new roll of paper on the holder.
- Insert the end of the paper into the paper feeder, as shown in the figure below, and wait until it starts scrolling automatically.

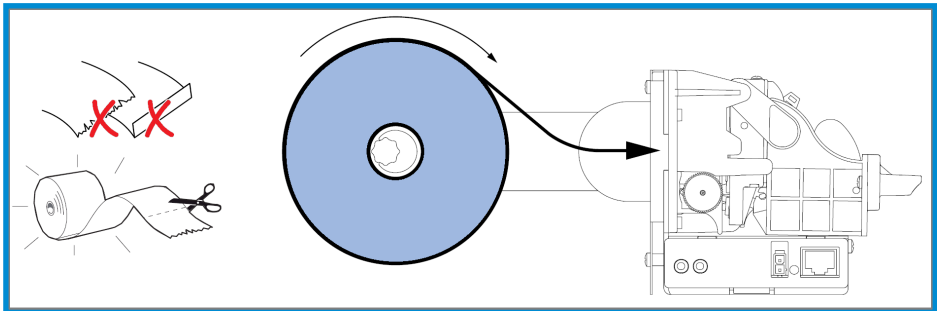

Fig.3.39.

**For more information, refer to the manual for the Custom TG2480 printer.**

## 3.9. Use of the Banking Terminal

---



**This function is optional. If you doubt the availability or absence of this function, you can clarify this information from the manufacturer.**



**The bank terminal is not included in the package and is purchased separately under the acquiring agreement.**



**Consultation and services related to the operation of the terminal are carried out in accordance with the acquiring agreement. The terminal is installed by the Promobot service personnel.**



---

## 3.10. Card dispenser

---



**This function is optional. If you doubt the availability or absence of this function, you can clarify this information from the manufacturer.**

The dispenser is compatible with the following card standards:

- The size of the card: 55x86 mm.
- Thickness of the card: 0.2-1.2 mm (at  $\geq 1.2$  mm additional adjustment is required, default: 0.8 mm).
- Capacity: up to 500 cards (185 cards with a card thickness of 0.76 mm)

### The process of giving out

The dispenser allows you to give out and take cards (depends on the selected mode of operation). Depending on the set position, the given card will be exposed from the device opening, or it will be completely out of the opening when dispensed. The dispenser also supports the capture of the card back if it remains in the device. The captured and received cards are stored in the separate compartments.

**More detailed information can be found in the specification for the card issuing device CRT-531.**

## 4. Periodic maintenance

For normal operation of Promobot, it is necessary to carry out **periodic preventive maintenance**.

Service Information:

Name of work	Periodicity
Updating the software	as it released
Analysis of the system log	every month
Lubrication of moving parts of the robot	every month
Carrying out works to inspect and check the	every 4 months
Verification of the operation of the equipment and parts of the robot (telemetry, data recording, voice recognition, face recognition, ana-	every 4 months
Monitoring voltage and current consumption	every 4 months
Functional test in all modes	every 6 months
Cleaning the disk space of the robot from unused promotional materials, video recordings and photos	every 6 months
Checking the robot battery	once a year



**Maintenance is performed by the service center.**

- The serviceability is determined by external inspection, then by turning on and checking the main parameters.
- If the conditions of operation, storage and timely troubleshooting are observed, the robot can be operated for a long time.
- Regularly wipe the robot body with a damp cloth.
- Do not use abrasives or solvents for cleaning.
- Do not use harsh chemicals (acids, etc.) that can react with the plastic parts of the enclosure.
- Do not let liquid enter the interior of the robot, do not immerse it in liquid, do not wash it with running water.
- The robot in the manufacturer's packaging can be transported by all types of covered transport at an air temperature of +10°C to +35°C and relative humidity up to 70%.
- In case of transportation of the robot at negative temperatures, before switching on, be sure to let the robot warm up to a temperature at least +10°C.
- When transporting, any possible impacts and movements with the robot inside the vehicle should be avoided.
- The robot should be stored in a heated, ventilated area, out of reach of children, excluding direct sunlight from 0°C to + 40°C and 65% relative humidity (+ 25°C).
- At the end of its service life, the robot must be disposed of in accordance with the rules, regulations and methods of its current location.

## 5. Warranty conditions

1. Reliable operation of this product during the entire service life is the subject of special care of our service centers. In case of any problems during the operation of the product, we recommend that you contact only our service centers.
2. When purchasing a product, check its completeness and serviceability.
3. In order to avoid misunderstandings, we kindly ask you to carefully read the instructions for use before working with the product.
4. The legal basis of these guarantee conditions is the current Legislation.
5. The warranty period for this product is 12 months and is calculated from the time of delivery. In case of elimination of product defects, the warranty period is extended for a period during which it was not used.
6. The service life of the product directly depends on the operating conditions.
7. Our warranty does not apply to product malfunctions caused by:
  - Non-compliance by the user with the instruction manual for the product;
  - Mechanical damage caused by external shock or any other impact;
  - Use of the product for other purposes;
  - Natural disaster;
  - Unfavorable atmospheric and other external impacts on the product, such as rain, snow, high humidity, heating, corrosive environments;

- Use of accessories, consumables and spare parts not recommended or approved by the manufacturer;
  - Penetration of foreign objects, insects, animals, materials or substances into the product;
  - For devices that have been opened, repaired or modified outside the authorized service center;
  - For accessories, parts that have failed due to normal wear, such as body parts and consumables, including servos, LEDs, screw connections;
  - Faults caused by overloading, resulting in the failure of electric motors, servo drives, switches, monitors and other components, parts. Unconditional signs of product overload include, among others: destruction of the matrix of displays, deformation or melting of parts and components of the product, darkening or charring of wire insulation under the influence of high temperature.
8. The manufacturer undertakes, during the warranty period of operation, to repair product defects or replace it without compensation, if the defects did not arise as a result of the buyer's violation of the rules for the use of the product or its storage. Warranty repair of the robot is performed by the manufacturer's service centers.

## 6. Contacts

Promobot

Phone: +7 (342) 257-80-85

Email: info@promo-bot.ru

Address: 7, Rabochaya str., Perm, Russia

Wording: May 2019

